

UNI- EDGE

BOLTLESS STEEL SHELVING AND ACCESSORIES

APPLICATIONS:

Commercial filing, documentation, archives, small parts and computer spools, video/audio tapes etc.



CORPORATE PROFILE

Universal Storage Systems, Africa's leading manufacturer of racking and shelving, markets a range of warehousing and storage products and systems.

The company, through the use of its own research, technology and highly trained engineers, plus access through international relationships, has a reputation of being able to develop solutions for most storage challenges.

Serving the Republic, through a network of company branches and distribution centres, Universal Storage Systems has developed a reputation for excellence in South Africa. The company has also established an expanding base of export countries-such as the Middle East, Australia, Africa and the UK.

UNI - EDGE

Visit our Web Site: www.universal-storage.co.za

Smooth lines and easy adjustability.

Ideal for document and tape storage.

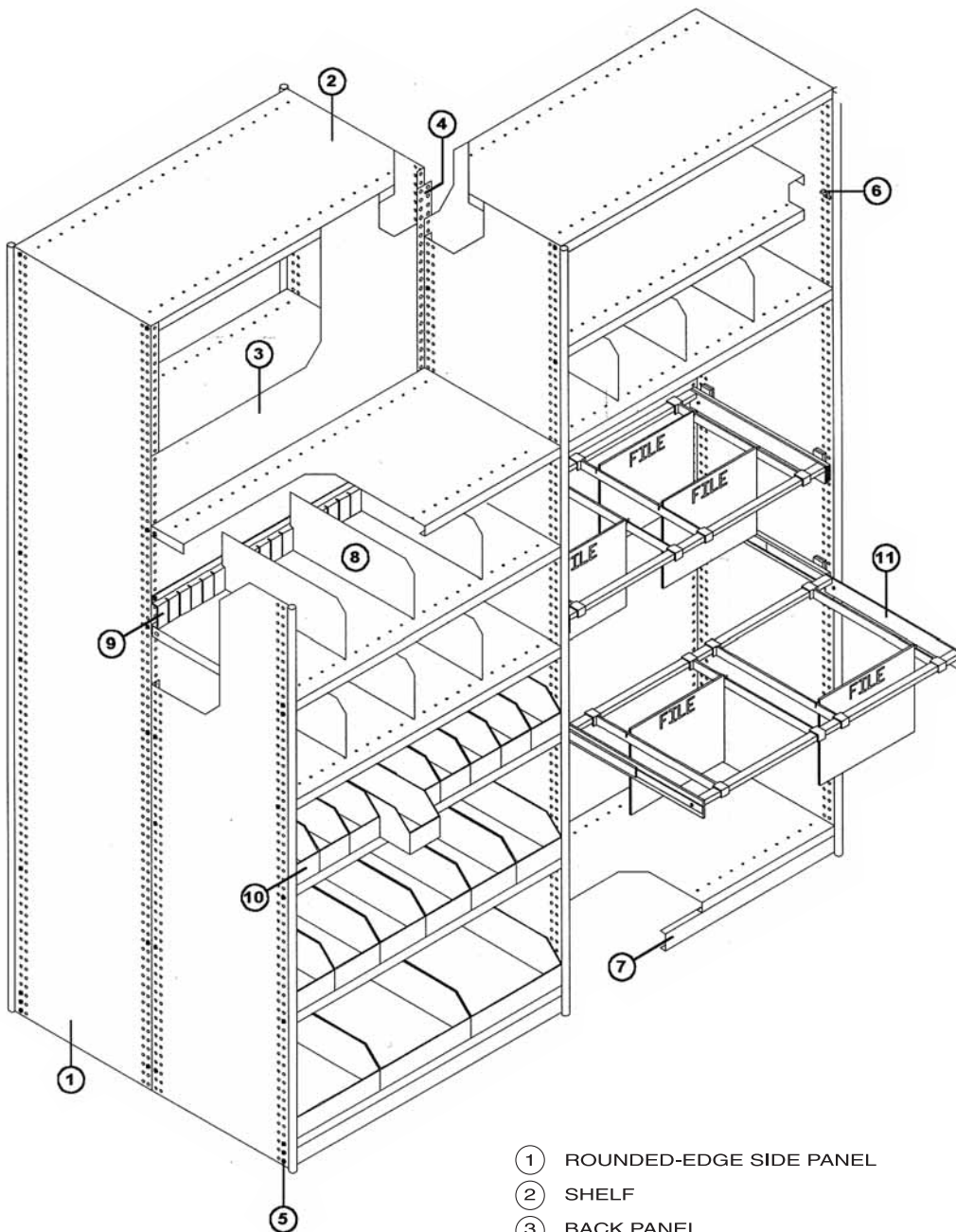

- ① ROUNDED-EDGE SIDE PANEL
- ② SHELF
- ③ BACK PANEL
- ④ COVER STRIP
- ⑤ GUTTER BOLT & NUT
- ⑥ ADJUSTABLE SHELF-CLIP
- ⑦ BASE PANEL
- ⑧ QUICK-ADJUSTABLE DIVIDER
- ⑨ DECK SUPPORT
- ⑩ SHELF PIN
- ⑪ PULL-OUT FILE CRADLE

UNI-EDGE



BOLTLESS STEEL SHELVING AND ACCESSORIES

- **Static Cladded Shelving**
- **Mobile Cladded Shelving**

Johannesburg
Tel: 011- 793-1111/2/3
Fax: 011- 793-4920
E-mail:
info@universal-storage.co.za

Cape Town
Tel: 021- 534-3560 • Fax: 021- 534-3591
E-mail: capetown@ct.universal-storage.co.za

Durban
Tel: 031-700-9666 • Fax: 031-700-9144
E-mail: durban@universal-storage.co.za

Visit our Web Site: www.universal-storage.co.za

UNIVERSAL
STORAGE SYSTEMS
ISO 9001
QUALITY ENDORSED COMPANY